

The **VBM 200X** is part of a range of manual bi-mixer dispensers, designed for use with high viscosity sealants and adhesives.

## Specifications

- Lightweight: 1.6kg / 3.5lbs
- Cartridge Holder Length: 211mm / 8.3in
- Maximum Thrust: 4.5kN
- Handle Material: Epoxy Coated Aluminum
- Frame Material: Epoxy Coated Steel
- Tool Component Approvals: REACH
- Cartridge Capacity: 400mL (7.0oz)
- Cartridge Ratio: 1:1
- Mechanical Advantage Ratio: 25:1
- Viscosity: High
- Standard Color: Black/Blue
- Customized Versions: Yes

## Dimensions

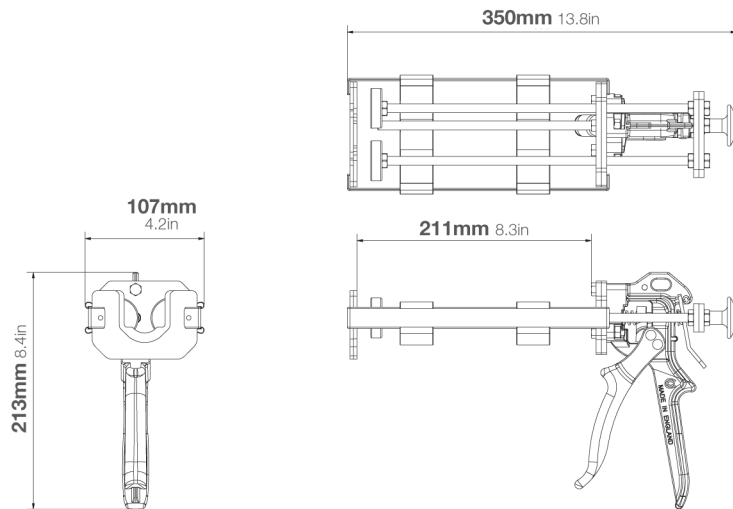

## Matching MIXPAC™ side-by-side cartridges



**C-System / F-System**  
400mL / 1:1 PP/PA

## Compatible side-by-side cartridges

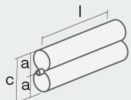

**Plastic Cartridge**  
400mL / 1:1 PP/PBT

1:1	mm	inch
l	185.0	7.28
a	Ø45.0	Ø1.77
c	93.0	3.66

## Conversion kits

## Matching accessories